

Operation Manual

MODEL

1455 -A, -AH,, -AL, -B, -BH

Decade Voltage Divider



IET LABS, INC.

534 Main Street, Westbury, NY 11590

TEL: (516) 334-5959 • (800) 899-8438 • FAX (516) 334-5988

www.ietlabs.com



IET LABS, INC.

534 Main Street, Westbury, NY 11590

Tel (516) 334-5959 (800) 899-8438 Fax (516) 334-5988 <http://www.ietlabs.com>

Manual & Programmable Standards, Substitutes, & Test Instruments

- New Products
- Find a Product
- Technical Applications
- Request a Quote
- Price List
- Place an Order
- Request a Catalog
- Contact Us
- About IET

If you need products or service by Genrad, esi, Biddle, or others.

STANDARDS, DECADES STROBES

Formerly Manufactured By:
QuadTech/GenRad(General Radio)

*Now being manufactured,
serviced, calibrated,
and fully supported
by IET LABS*

COST-EFFECTIVE QUALITY
STANDARD OR CUSTOM SOLUTION
R-L-C • RTD • VOLTAGE
CURRENT • PROCESS CONTROL

Product Area of Interest



Widest Choice
of Decades

IET is compliant with ISO 9001,
ISO/IEC 17025, ANSI Z540-1-1994,
and MIL-STD-45662A

Calibration Test Measurement Metrology

[Find a Products](#) | [Technical Applications](#) | [Request a Quote](#) | [Place an Order](#) | [Free Offer](#) | [Request a Catalog](#) | [Contact Us](#)

© Copyright 1999 - 2001 IET Labs, Inc. All rights reserved.
Problems or Comments? Contact webmaster@ietlabs.com

To navigate our easy to use website for quick access to specifications and prices:

1. Select **Find a Product** to go to a convenient scrolling thumbnail catalog and then to detailed data sheets as desired; or:
2. Select **STANDARDS DECADES STROBES** for products formerly manufactured by GenRad (General Radio) or QuadTech.

Since 1976, IET labs has had a long-standing commitment to conform the instruments and standards we offer to the customer's needs rather than to have the customer settle for what is available. We devote our customer service and applications entirely to the customer's satisfaction in the quality standards, test instruments and calibration service we provide.

- Combinations of functions, special ranges, ratings, or accuracies.
- Replacement for discontinued models from other manufacturers.
- Calibration and repair services - NIST traceable.
- Compliant with ISO 9001, ISO 17025, ANSI Z540-1-1994, and MIL-STD-45662A.

Capabilities

- R: 20 $\mu\Omega$ -1 T Ω
- C: <1 pF - 1 F
- L: 100 μ H-100 H
- Accuracy to 1 ppm
- Resolution to 0.1 ppm
- Voltage to 20 kV
- Power to over 1000 W
- Programmable IEEE-488 or BCD



*The World Standard in Metrology
Since 1915*
Now continuing the GenRad tradition

Featuring instruments formerly
manufactured by
GenRad/General Radio/QuadTech

SPECIFICATIONS

Type	1455-AH	-A	-AL	-BH	-B
Dials:	4	4	4	5	5
Input Resistance:	100 kΩ	10 kΩ	1 kΩ	100 kΩ	10 kΩ
Input Voltage Rating: May be 20 ppm linearity change at full rating (see below)	700 V	230 V	70 V	700 V	230 V
Frequency Response (f_o at 3 dB down): (unloaded, at max output resistance setting)	85 kHz	850 kHz	7.5 MHz	69 kHz	690 kHz
Resolution (in ppm of input):	100	100	100	10	10
Linearity					
Absolute Linearity (in ppm of input): Output taken with respect to output zero setting at low audio frequencies with input voltage < 1/2 rating.					
Ratio					
0.00001 to 0.00010	—	—	—	± 0.02	± 0.03
0.00010 to 0.00100	± 0.2	± 0.3	± 0.7	± 0.2	± 0.3
0.00100 to 0.01000	± 2	± 2	± 3	± 2	± 2
0.01000 to 0.10000	± 15	± 15	± 20	± 10	± 10
0.10000 to 1.00000	± 30	± 30	± 50	± 20	± 20
Terminal Linearity (in ppm of input) (add to absolute linearity):					
Four-terminal (output with respect to low output terminal):	± 0.004	± 0.04	± 0.4	± 0.004	± 0.04
Three-terminal (low terminals common, or output with respect to low input terminal):	± 0.02	± 0.2	± 2	± 0.02	± 0.2
Max Output Resistance: (input shorted)	27.9 kΩ	2.79 kΩ	333 Ω	28.8 kΩ	2.88 kΩ
Effective Output Capacitance: (typical, unloaded)	67 pF	67 pF	67 pF	80 pF	80 pF

Frequency Characteristic:

Acts like simple RC circuit below f_o so that

$$\frac{E_o}{E_{in}} \approx \frac{\text{reading}}{\sqrt{1 + \left(\frac{f}{f_o}\right)^2}}$$

Tabulated value of f_o is at setting that gives max output resistance so that f_o at all other settings is higher. At $0.044f_o$, response is down < 0.1%.

Accuracy of Input Resistance: +0.015%, except for 1455-AL, which is +0.025%.

Temperature Coefficient: < 20 ppm for each resistor. Since voltage ratios are determined by

resistors of similar construction, net ambient temperature effects are very small.

Dimensions (width × height × depth): Rack models, 19 × 3 1/2 × 4 5/8 in. (485 × 89 × 120 mm); 4-dial bench models, 14 3/4 × 3 1/2 × 6 in. (375 × 89 × 155 mm); 5-dial bench models, 17 1/8 × 3 1/2 × 6 in. (455 × 89 × 155 mm).

Net Weight: Bench models, 4-dial, 6 3/4 lb (3.1 kg); 5-dial, 7 3/4 lb (3.6 kg).

Shipping Weight (est.): Bench models, 4-dial, 7 1/2 lb (3.5 kg); 5-dial, 8 1/2 lb (3.9 kg).

Add approx 1 lb (0.5 kg) to net and shipping weights for rack models.

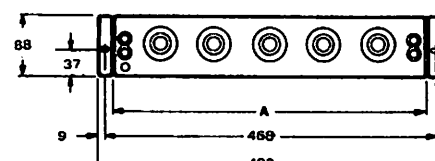
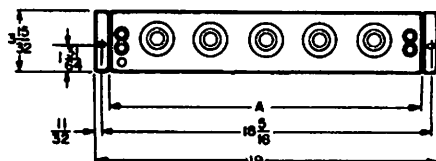
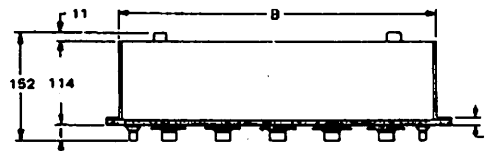
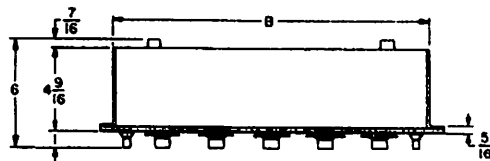

Dimensions
in. mm

DIMENSIONS ARE IN INCHES.

Type 1455-

	A	B	A	B
A, AH, AL	14 3/4	14 15/16	370	380
B, BH	17 5/16	17 1/2	440	445

DIMENSIONS ARE IN MM.

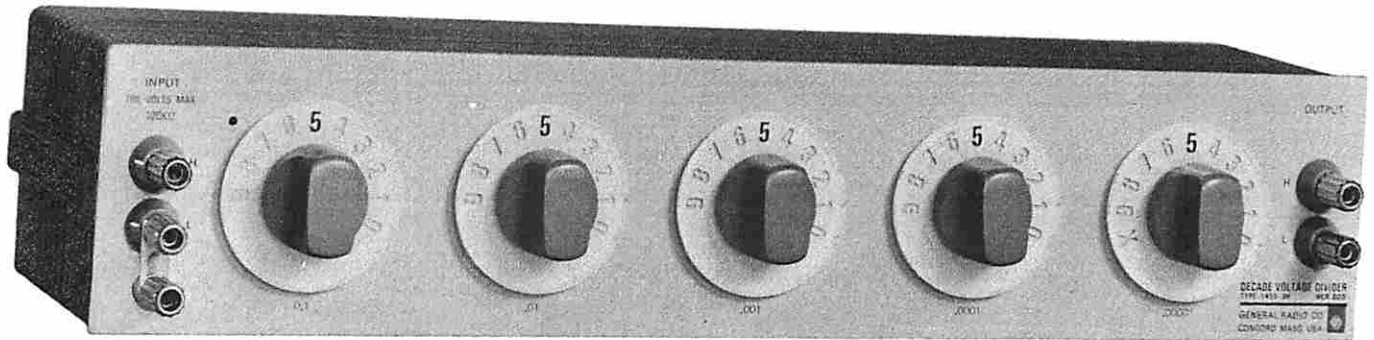

Figure 1-1. The Type 1455-BH Decade Voltage Divider.

SECTION 1

INTRODUCTION

1.1 PURPOSE.

The Type 1455 Decade Voltage Divider is a convenient means of obtaining accurately known voltage ratios. Among its many uses are the calibration of voltmeters, linearity measurements on continuously adjustable transformers and potentiometers, measurement of gain and attenuation, the precise measurement of frequency-response characteristics of audio-frequency networks, and the determination of turns ratios in transformers.

Five models are available in order to provide a choice in resolution and impedance level. The high-impedance models, Types 1455-AH and -BH, permit greater applied voltage (up to 700 V), while the lowest-impedance model, Type 1455-AL, has useful accuracy in the radio-frequency range.

1.2 DESCRIPTION.

These voltage dividers are housed in a 3 1/2''-high cabinet. All models are available for either bench use or for installation in a relay rack. Refer to Table 1-1.

The panel binding posts are for general use, and connection to the instrument may also be made at the rear, as is often preferred for rack-mounted equipment.

The Types 1455-AH, -A, and -AL have four selector switches for four-digit readout. The Types 1455-BH and -B have five decade switches for five-digit readout. These switches indicate the voltage-ratio setting in an in-line readout with the decimal point always before the first digit (refer to paragraph 2.3).

1.3 ACCESSORIES AVAILABLE.

Panel-Adaptor Sets are supplied with the Type 1455 relay-rack models listed in Table 1-1. Panel-Adaptor Sets are also available for mounting Type 1455 bench instruments in a standard 19-inch relay rack (refer to Table 1-2).

Table 1-2
TYPE 1455 PANEL-ADAPTOR SETS

Catalog Number	Description
0480-2060	Panel-Adaptor Set for Types 1455-A, -AH, and -AL.
0480-2020	Panel-Adaptor Set for Types 1455-B and -BH.

Table 1-1
TYPE 1455 DECAD VOLTAGE DIVIDERS

Catalog Number		Type	No. of Decades	Ratio Range
Bench	Relay Rack			
1455-9700	1455-9701	1455-A	} 4	0.0001 to 1.0
1455-9702	1455-9703	1455-AH		
1455-9704	1455-9705	1455-AL		
1455-9706	1455-9707	1455-B		
1455-9708	1455-9709	1455-BH	} 5	0.00001 to 1.0

SECTION 2

OPERATING PROCEDURE

2.1 INSTALLATION.

To install a Type 1455 Decade Voltage Divider in a standard 19-inch relay rack using the appropriate Panel-Adaptor Set, refer to Figure 2-1 and proceed as follows:

a. Remove the black nylon buttons from the holes in the side panels of the instrument. These buttons are press fitted and are easily removed with a small screwdriver.

b. Install the adaptor panel (A) on each side of the instrument, using the 3/8-inch locking screws (B) supplied. The holes in the side panels are tapped to receive these screws.

c. Mount the assembly in a standard 19-inch relay-rack cabinet, using the 5/8-inch No. 10-32 screws (C) and nylon washers (D) supplied.

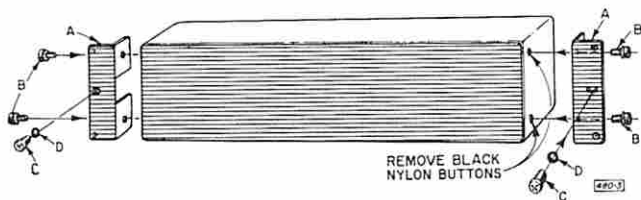

Figure 2-1. Relay-rack installation of a Type 1455 Decade Voltage Divider.

2.2 CONNECTIONS.

2.2.1 FRONT-PANEL CONNECTIONS.

Connect the external voltage source to the two insulated INPUT terminals. If grounded operation is to be used, connect the ground link between the lower INPUT grounded terminal and the middle (insulated) terminal. Connect the device to be supplied to the OUTPUT terminals.

2.2.2 REAR CONNECTIONS.

To make connections at the rear of the instrument, refer to Figure 2-2 and proceed as follows:

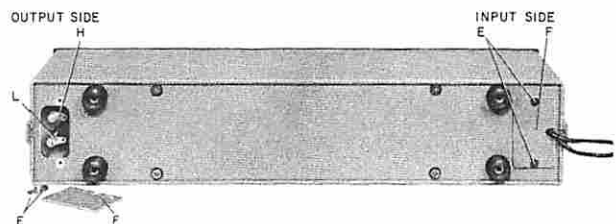

Figure 2-2. Rear view of Type 1455 showing OUTPUT terminals and INPUT side fully connected.

a. Remove the two 6-32 screws (E) and the small rectangular plate (F) from the INPUT side of the rear panel. (The terminals on the front panel, except for the lower INPUT grounded terminal, extend directly to the rear and are available for connection when the rear plates are removed.)

b. Connect the voltage source to the recessed INPUT terminals at the rear. If grounded operation is desired, connect the ground link between the lower INPUT grounded terminal and the middle (insulated) terminal on the front panel.

c. Remount plate (F) on the rear panel, using the two screws (E) previously removed.

NOTE

In order to provide an opening for the connection leads, plate (F) must be mounted with its slot facing toward the side panel of the instrument. To seal the instrument from outside dust and dirt when connections are not required at the rear, mount plate (F) with its slot facing away from the side panel.

d. At the OUTPUT side of the rear panel, repeat step a above, connect the device to be supplied to the rear OUTPUT terminals (H and L), and remount plate (F) as described in step c.

2.3 OPERATION.

Remember that the voltage divider, like any potentiometer, should be used only with high resistance loads. Refer to paragraph 2.7.

Set the selector switches to indicate the desired voltage ratio. When setting the switches remember that $X = 10$, and the decimal point is always placed before the first digit. For example, if the output voltage is to be 0.1240 times the input voltage, the switches can be set (from left to right, respectively) to:

1, 2, 4, 0 = 0.1240

or

1, 2, 3, X = 0.1240

And if a ratio of 1.0000 is desired, set the switches to:

9, 9, 9, X = 1.0000

2.4 TYPICAL USES.

2.4.1 CALIBRATION OF A VTVM.

The simple circuit of Figure 2-3 is useful for checking electronic, low-frequency ac or dc voltmeters which have an input impedance much higher than the output impedance of the divider. The Type 1455-AL is particularly useful for low-voltage ac calibration because of its lower output impedance and better frequency characteristics. In this circuit, the standard meter should be used with a reading near full scale to obtain the best accuracy.

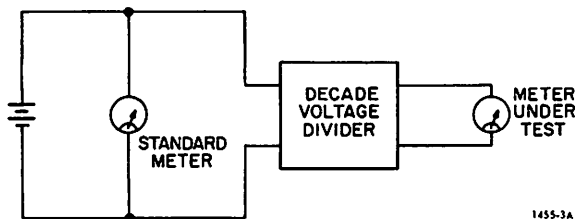

Figure 2-3. Circuit for vacuum-tube voltmeter calibration and test, using a Type 1455 Decade Voltage Divider.

2.4.2 LINEARITY CHECKS OF POTENTIOMETERS.

The linearity of potentiometers and other voltage dividers can be checked using the circuits shown in Figure 2-4 and Figure 2-5. Both circuits are essentially Wheatstone bridges.

The circuit of Figure 2-4 is preferable if the potentiometer or divider under test has a resistance higher than that of the divider.

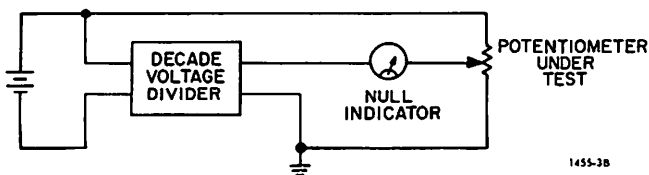

Figure 2-4. Type 1455 Decade Voltage Divider in null circuit used for linearity test of a high-resistance potentiometer.

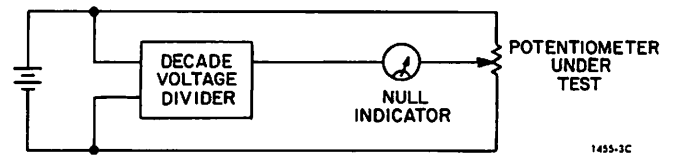

Figure 2-5. Null circuit for linearity test of a low-resistance potentiometer, using a Type 1455 Decade Voltage Divider.

The circuit of Figure 2-5 is preferable if the impedance of the device under test is lower than that of the divider. In either of these circuits, when the divider is adjusted to give a null indication, no current is drawn from the divider and the open-circuit calibration is correct.

These circuits may also be useful at audio frequencies, but capacitive-loading effects must be considered in order to obtain a null, and to obtain the desired accuracy at a null. The null detector should either be battery-operated and floating (GR 1232 Tuned Amplifier and Null Detector) or isolated from the circuit by a shielded transformer (GR 578 Shielded Transformer). In either case, the larger output capacitance should be placed across the device with the lower output impedance in order to reduce loading and phase-shift errors. It may be necessary to add additional capacitance to obtain a null.

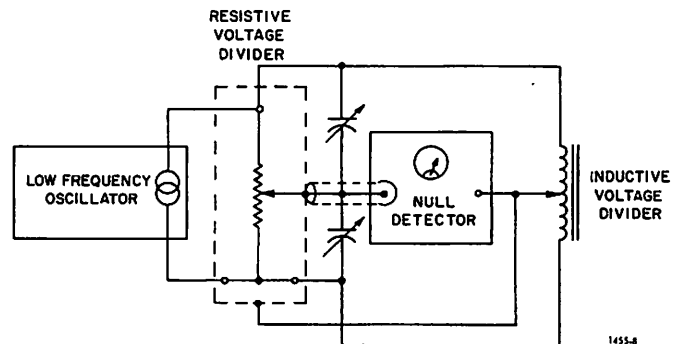

Figure 2-6. An ac null circuit for linearity test of an inductive voltage divider, using a resistive (Type 1455) voltage divider.

An example of an ac circuit is shown in Figure 2-6. Here, the transformer-type divider has a much lower output impedance than that of the resistive divider, so that the low-side of the detector and the case of the resistive divider are both tied to the output.

2.5 EFFECTS OF TEMPERATURE.

Since all resistors are of similar construction and have more or less equal temperature coefficients, the effects of changes in ambient temperature are very small. The effects from self-heating are not balanced out, however. In Figure 3-1, note that in the first decade between contacts 7 and 9, which are bridged by the second decade, only half of the input current is carried. The resistors between these points will have only one-quarter of the temperature rise of other resistors in the decade, causing an error in the output voltage. The temperature rise of

the following decades is negligible. The temperature effect is greatest at the zero position of the first decade.

To keep the self-heating error at the first decade within specifications, limit the input voltage to the divider to one-half of the maximum voltage rating.

In dc measurements at very low levels, substantial error can result from thermal emf's at the junctions of dissimilar metals. The Type 1455 Decade Voltage Dividers use gold-plated copper binding posts to minimize these voltages when connections are made with copper wire.

2.6 FREQUENCY RESPONSE.

The Type 1455 Decade Voltage Dividers act very much like simple RC low-pass filters at frequencies below their 3-dB cutoff frequency (f_0). Thus, attenuation at any frequency below f_0 can be determined from the expression:

$$\frac{E_{out}}{E_{in}} = \frac{N}{\sqrt{1 + \left(\frac{f}{f_0}\right)^2}}$$

where:

N = divider setting
f = operating frequency

In the specifications, the value of f_0 is given for the setting which gives the maximum output resistance (refer to paragraph 2.7), with no additional capacitance on the OUTPUT terminals, and with the case connected to the low INPUT terminal. For any other setting, f_0 is higher, and additional capacitance on the output will reduce f_0 which is inversely proportional to $R_{out} \times C_{out}$. The effective internal-loading capacitance is also given in the specifications to facilitate the calculation of values of f_0 when external capacitance is added.

In some measurement circuits, such as the circuit shown in Figure 2-6, it is possible to connect the divider case to a voltage equal to the output voltage. This greatly reduces the effect of stray capacitance and makes it possible to obtain extremely precise ac measurements even with the high-resistance models (Types 1455-AH and -BH).

At settings near zero, the inductance of the wiring (approximately 0.7 μ H) introduces a small error which is proportional to frequency and is equal to approximately 0.1 ppm at 10 kHz.

2.7 OUTPUT RESISTANCE.

The decimal ratio in the Type 1455 dividers is the ratio of the open-circuit output voltage to the input voltage. The divider is intended primarily for use with high-impedance loads, such as a null indicator or high-impedance voltmeter. For finite load resistances, it is necessary to know the output resistance in order to determine the actual output voltage of the divider. The loaded output voltage (E_o) can be determined by the expression:

$$E_o = N \frac{R_L}{R_L + R_o}$$

where:

N = divider setting
 R_L = load resistance
 R_o = output resistance

To the first approximation, the output resistance is that of a simple divider (see Figure 2-7). For this circuit, with the input shorted, the output resistance (R_o) is:

$$R_o = N(1-N)R_{in}$$

where:

N = divider setting
 R_{in} = input resistance

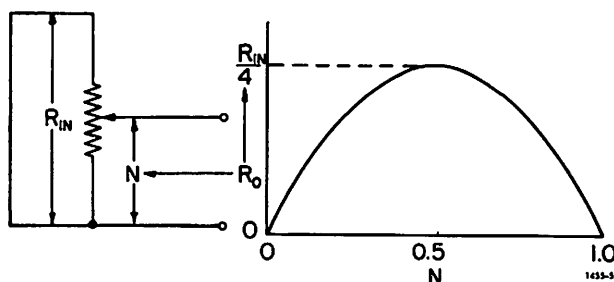

Figure 2-7. Output-resistance characteristic of a simple divider.

Actually, the Type 1455 divider circuit is substantially more complicated than a simple divider; and the actual output resistance for any given setting is difficult to calculate. Output resistance values for combinations of the first two digits (with other digits set at zero) are given in Table 2-1 for Type 1455-A and -B. The output resistance values for the Types -AH and -BH are those given in Table 2-1 but multiplied by a factor of 10. For the Type 1455-AL, multiply by 0.1.

Note that it is not possible to interpolate between values given in Table 2-1. The resistance is always increased if subsequent digits are set to other than

Table 2-1
OUTPUT RESISTANCE* FOR TYPES 1455-A, -B

		Second Selector - Switch Setting									
		0.00	0.01	0.02	0.03	0.04	0.05	0.06	0.07	0.08	0.09
First Selector - Switch Setting	0	0	189	356	501	624	725	804	861	896	909
	0.1	900	1069	1216	1341	1444	1525	1584	1621	1636	1629
	0.2	1600	1749	1876	1981	2064	2125	2164	2181	2176	2149
	0.3	2100	2229	2336	2421	2484	2525	2544	2541	2516	2469
	0.4	2400	2509	2596	2661	2704	2725	2724	2701	2656	2589
	0.5	2500	2589	2656	2701	2724	2725	2704	2661	2596	2509
	0.6	2400	2469	2516	2541	2544	2525	2484	2421	2336	2229
	0.7	2100	2149	2176	2181	2164	2125	2064	1981	1876	1749
	0.8	1600	1629	1636	1621	1584	1525	1444	1341	1216	1069
	0.9	900	909	896	861	804	725	624	501	356	189

* Values given are for combinations of settings for first two digits, with other digits set at zero.
INPUT TERMINALS SHORTED.

zero. The highest output resistance (given in the specifications) is at settings 5455 for the four-digit dividers, and 54545 for the five-digit models. Output resistance for other settings may be most easily found by resistance measurement.

If the generator has a finite impedance, and the voltage is measured before this impedance instead of at the divider, the ratio with respect to this generator voltage will be in error. However, if the load impedance is infinite, the ratio of any two settings will be correct because the input impedance of an unloaded divider of this type is constant.

If both the generator and load impedances are finite and relative ratios are desired, the equivalent output impedance should be measured with the INPUT terminals connected through an impedance equal to that of the generator, and corrections should be made as shown above.

SECTION 3

PRINCIPLES OF OPERATION

3.1 CIRCUIT DESCRIPTION.

The method of voltage division, which is attributed to Kelvin and Varley, is shown by the schematic diagram for the Type 1455-A, Figure 3-1. Eleven

equal resistors are used in all but the last decade. Two of these resistors are shunted by the next decade which uses resistors of one-fifth the value of those in the preceding decade. In this manner, each decade effectively becomes a string of ten equal resistors giving the desired decimal readout on the dial.

The Type 1455-AH uses resistors of ten times the values shown in Figure 3-1. On the Types 1455-AL, -B, and -BH, additional fixed resistors are added across the input of the later decades in order to avoid the necessity of using very low-value resistors which would be less accurate and stable.

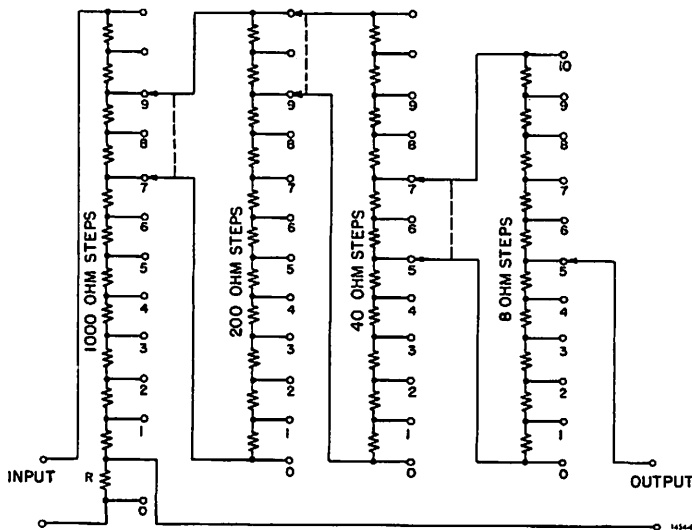

Figure 3-1. Elementary schematic diagram of Type 1455-A Decade Voltage Divider.

3.2 INTERPRETATION OF LINEARITY SPECIFICATIONS.

3.2.1 LINEARITY AND ACCURACY.

The linearity specification for the Type 1455 is given in ppm (parts-per-million) of the input voltage. This specification is similar to a voltmeter accuracy specification given in percent-of-full scale. At any setting, the difference between the input voltage multiplied by the setting and the output voltage will be less than the specified ppm of the input voltage.

In terms of percentage of setting, the accuracy is equal to the specified linearity divided by the setting. Because the setting is never greater than unity, the accuracy, as a percent of setting, is always a larger number than the linearity specification. For

very low settings the linearity, as a fraction of input, becomes a very small number. The accuracy, as a percent, of these low settings is actually poorer than that of higher settings, because somewhat lower tolerance resistors are used on the higher digits.

3.2.2 ABSOLUTE LINEARITY.

For very low settings, the resistance of the wiring and switches add small, but noticeable errors, because at the zero setting the output is not exactly zero. This error can be ignored if the output at any setting is taken with respect to the actual output voltage at the zero setting. This is shown in Figure 3-2 where the errors are greatly exaggerated for the purpose of illustration. Here, the output voltage at zero setting is substantial. Also, the output at full scale does not equal the input. Absolute linearity is a measure of how far the output voltage differs from a straight line drawn between the output voltages at the zero and full-scale settings, even though the voltages at these points are not exactly equal to zero and unity.

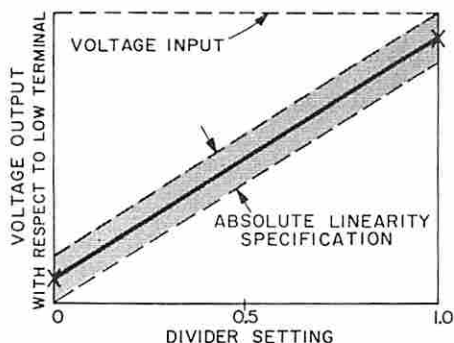

Figure 3-2. Exaggerated illustration of absolute linearity of a Type 1455.

An example of the use of absolute linearity is the calibration of dividers using lead-compensation correction as in Figure 3-3. Here, potentiometers A and B are adjusted so that the 0 (zero) and 1 (one) settings of both dividers coincide.

3.2.3 TERMINAL LINEARITY.

The linearity of a voltage actually present at two terminals of a divider is called the terminal linearity.

When the output is taken across both OUTPUT terminals, all four divider terminals are in use. An example of a measurement using this four-terminal connection is shown in Figure 2-3. The error due to switch resistance (refer to paragraph 3.2.2) is compensated for when such a measurement is made. A small resistor (R, Figure 3-1) is added in series with the divider so that the low OUTPUT terminal is at very nearly the same voltage as the high OUTPUT terminal when the divider setting is at zero. This resistor is of the order of 0.001Ω and it will not affect calibration of the divider.

In some cases, the input and output connections must be tied together, or the output must be taken with respect to the low INPUT terminal. In such three-terminal applications, the compensating resistor (R, Figure 3-1) is not effective and an additional error is given in the specifications under Terminal Linearity. Examples of three-terminal operation are the comparison of two dividers and checking the linearity of potentiometers using the circuit shown in Figure 2-6. However, if the potentiometer under test is of high resistance (greater than the input resistance of the divider), there will be less error if it is connected to the low OUTPUT terminal of the divider as shown in Figure 2-4.

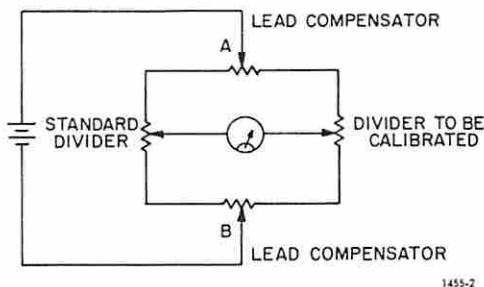

Figure 3-3. Divider calibration, using lead-compensation circuit.

SECTION 4

SERVICE AND MAINTENANCE

4.1 GR FIELD SERVICE.

Our warranty attests the quality of materials and workmanship in our products. When difficulties do occur, our service engineers will assist in any way possible. If the difficulty cannot be eliminated by use of the following service instructions, please write or phone the nearest GR service facility (see back page), giving full information of the trouble and of steps taken to remedy it. Describe the instrument by type, serial, and ID numbers. (Refer to front and rear panels.)

4.2 INSTRUMENT RETURN.

Before returning an instrument to GenRad for service, please ask our nearest office for a "Returned Material" number. Use of this number in correspondence and on a tag tied to the instrument will ensure proper handling and identification. After the initial warranty period, please avoid unnecessary delay by indicating how payment will be made, i.e., send a purchase-order number or (for transportation charges) request "C.O.D."

For return shipment, please use packaging that is adequate to protect the instrument from damage, i.e., equivalent to the original packaging. Advice may be obtained from any GR office.

4.3 MINIMUM PERFORMANCE STANDARDS.

The following procedure for checking linearity of Type 1455 Decade Voltage Dividers is recommended for incoming inspection or periodic operational testing.

NOTE

A thorough reading of paragraphs 2.4 through 2.7, and paragraph 3.2, will be helpful in preparing for linearity tests.

4.3.1 TEST EQUIPMENT.

The equipment listed in Table 4-1 is recommended for building the test circuit shown in Figure 4-1.

4.3.2 TEST PROCEDURE.

The circuit shown in Figure 4-1 is recommended for testing the linearity of Type 1455 Decade Voltage Dividers. Other variations of this circuit may be used, provided considerable care is observed in correcting for phase errors, and assuming the equipment used is precise enough for the results desired.

Table 4-1
TEST EQUIPMENT

Type	Minimum Requirements	Model Recommended*
Low-frequency oscillator	Range: 50 to 100 Hz Accuracy: $\pm 1\%$	GR 1311
Amplifier and null detector	Sensitivity: 0.1 μV over frequency range used. Gain: 120 dB.	GR 1232
Decade transformer divider (2 required)	Linearity: ± 1 digit in 10^{-6} decade, at 50 to 100 Hz. Phase error: $< 125 \mu\text{rad}$ for ratio settings from 0.001 to 1.0, at 1 kHz.	GR 1493

*GenRad models, or equivalent.

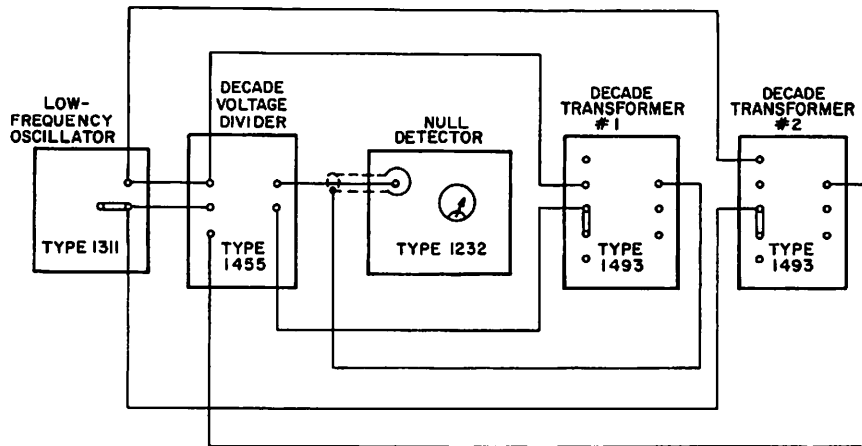

Figure 4-1. Linearity test of a Type 1455 Decade Voltage Divider using a General Radio oscillator, null detector, and two (Type 1493) Precision Decade Transformers.

When setting up the circuit in Figure 4-1, it is recommended that the operating frequency be set at 100 Hz. The procedure to check linearity is as follows:

- a. Set the Type 1455 for the ratio setting to be checked.
- b. Adjust the settings of the decade transformers to obtain a null.
- c. Observe the difference between the Type 1455 setting and the setting of decade transformer No 1. Compare this difference with the linearity tolerance specified for the Type 1455 setting, and for the particular model being tested.

4.4 PARTS REPLACEMENT.

4.4.1 GENERAL.

The Type 1455 Decade Voltage Divider is the type of instrument that should need little or no service over the years. If, however, the instrument does

not meet specifications at some point in its lifetime, it can be returned to General Radio for service, or it can be repaired by competent user personnel. Resistors R101 through R103 (see Figures 4-2 and 4-3) may be replaced with little difficulty. If other resistors (part of the switch assembly) are found to be faulty, it is recommended that the entire switch assembly be replaced. Use the parts list as a guide in determining which parts may be replaced individually, and those that should be replaced as an assembly.

4.4.2 KNOB REMOVAL – CAUTION.

The knobs on this instrument are mounted (snapped on) by engagement of a spring in a shaft detent. To remove the knob, grasp it with one hand and pull straight away from the panel. To avoid damage to the knob and other parts of the control, do not pry the knob loose with a screwdriver or similar flat tool, and do not attempt to twist the knob from the shaft.

PARTS LIST

Reference Number used with Type 1455-

A	AH	AL	B	BH	Description	Part Number
J101	J101	J101	J101	J101	JACK, Binding-post assembly	4060-0108
J102	J102	J102	J102	J102	JACK, Binding-post assembly	4060-0108
J103	J103	J103	J103	J103	JACK, Binding-post assembly	0938-2022
J104	J104	J104	J104	J104	JACK, Binding-post assembly	4060-0108
J105	J105	J105	J105	J105	JACK, Binding-post assembly	4060-0108
R101	R101	R101	R101	R101	RESISTOR, 1.6 m Ω (part of S101)	0510-8140
-	-	R102	-	-	RESISTOR, Wire-wound, 50 Ω \pm 0.035%	0500-0302
-	-	-	R102	-	RESISTOR, Wire-wound, 100 Ω \pm 0.025%	0500-0303
-	-	-	-	R102	RESISTOR, Wire-wound, 1 k Ω \pm 0.05%	0510-4870
-	-	R103	-	-	RESISTOR, Wire-wound, 80 Ω \pm 0.05%	0510-4700
-	-	S101	-	-	SWITCH ASSEMBLY, Rotary, 100 Ω /sect.	0510-4964
S101	-	-	S101	-	SWITCH ASSEMBLY, Rotary, 1 k Ω /sect.	0510-4967
-	S101	-	-	S101	SWITCH ASSEMBLY, Rotary, 10 k Ω /sect.	0510-4969
-	-	S102	-	-	SWITCH ASSEMBLY, Rotary, 20 Ω /sect.	0510-4961
S102	-	-	S102	-	SWITCH ASSEMBLY, Rotary, 200 Ω /sect.	0510-4965
-	S102	-	-	S102	SWITCH ASSEMBLY, Rotary, 2 k Ω /sect.	0510-4968
-	-	S103	-	-	SWITCH ASSEMBLY, Rotary, 20 Ω /sect.	0510-4961
S103	-	-	S103	-	SWITCH ASSEMBLY, Rotary, 40 Ω /sect.	0510-4962
-	S103	-	-	S103	SWITCH ASSEMBLY, Rotary, 400 Ω /sect.	0510-4966
S104	-	S104	-	-	SWITCH ASSEMBLY, Rotary, 8 Ω /sect.	0510-4960
-	-	-	S104	-	SWITCH ASSEMBLY, Rotary, 40 Ω /sect.	0510-4962
-	S104	-	-	-	SWITCH ASSEMBLY, Rotary, 80 Ω /sect.	0510-4963
-	-	-	-	S104	SWITCH ASSEMBLY, Rotary, 400 Ω /sect.	0510-4966
-	-	-	S105	-	SWITCH ASSEMBLY, Rotary, 8 Ω /sect.	0510-4960
-	-	-	-	S105	SWITCH ASSEMBLY, Rotary, 80 Ω /sect.	0510-4963
Mechanical Replacement Parts					KNOB ASSEMBLY	5500-5420
					DIAL ASSEMBLY, 0 to 9	5120-2031
					DIAL ASSEMBLY, 0 to X	5120-2033

NOTE: There are no Federal Stock Numbers for these parts.

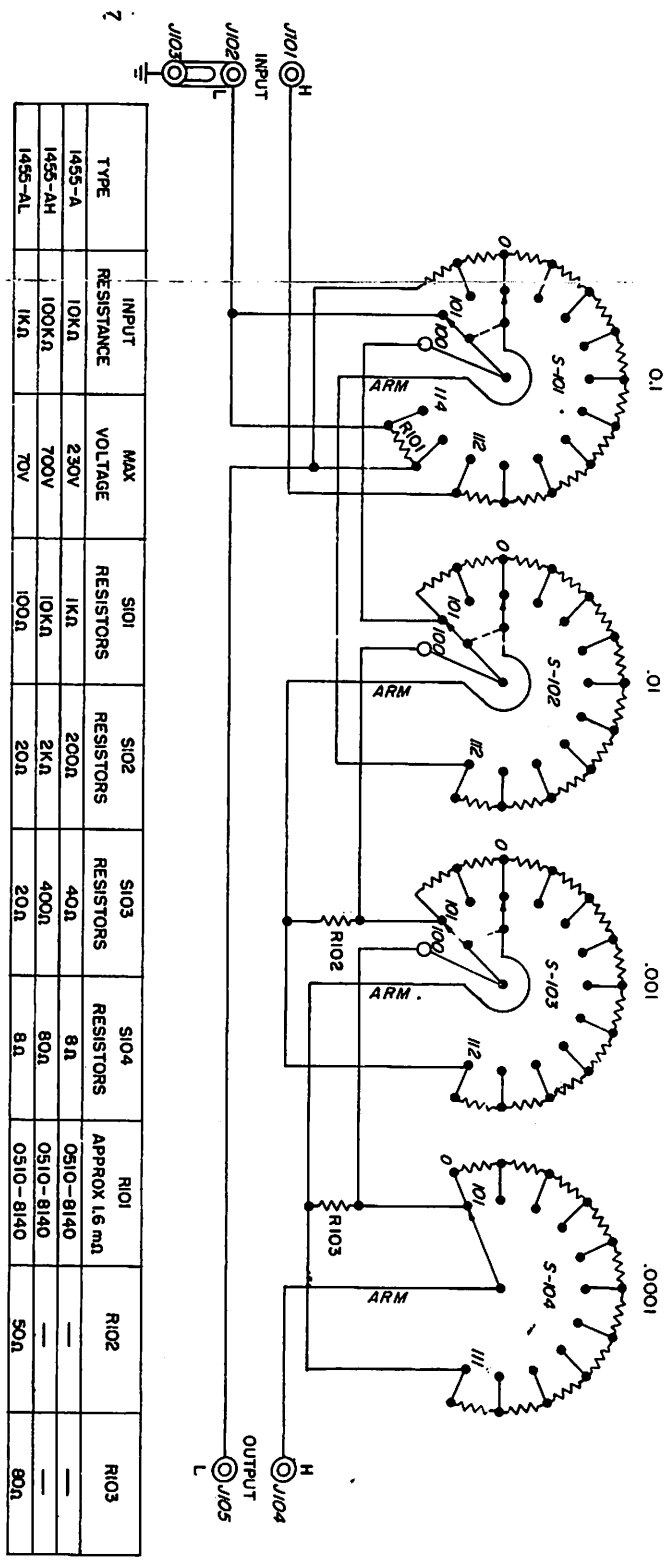

Figure 4-2. Schematic diagram for Type 1455-A, -AH, -AL Decade Voltage Dividers.

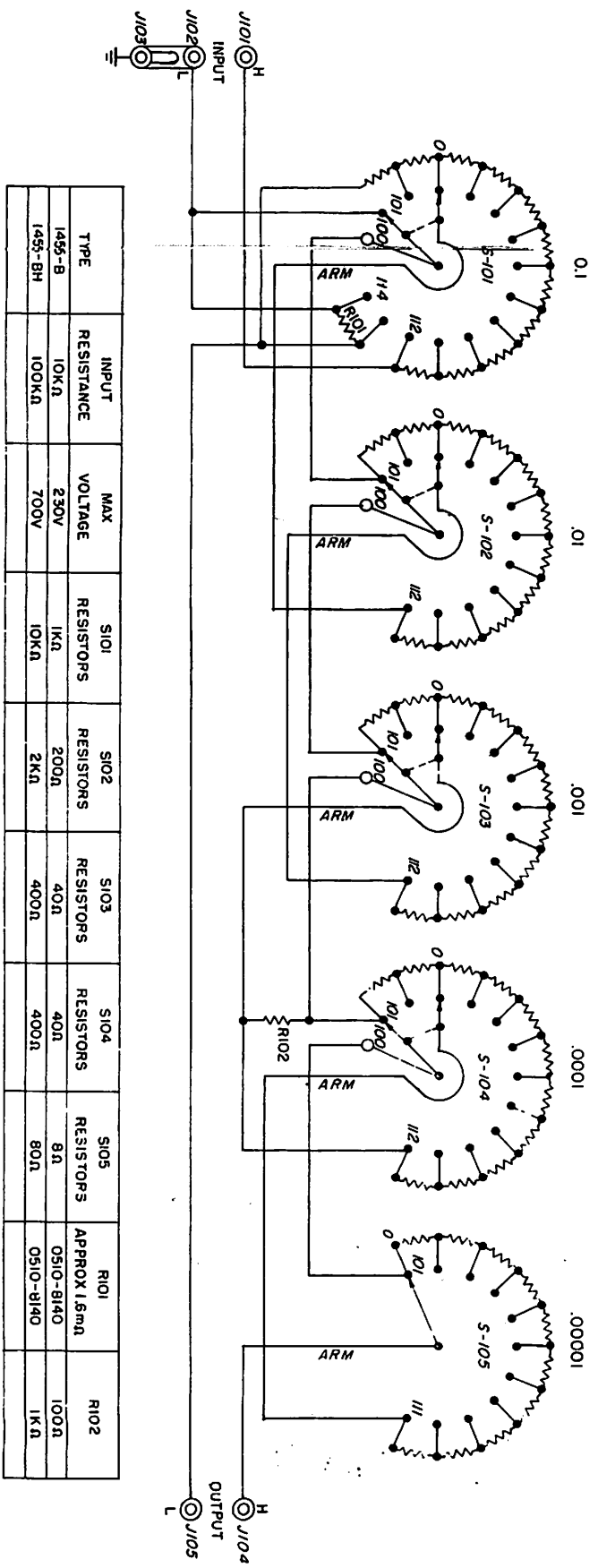

Figure 4-3. Schematic diagram for Type 1455-B, -BH Decade Voltage Dividers.



IET LABS, INC.

Standards • Decades • Strobes • Sound Level Meters • Bridges

Formerly manufactured by

GenRad

534 Main Street, Westbury, NY 11590

TEL: (516) 334-5959 • (800) 899-8438 • FAX: (516) 334-5988

www.ietlabs.com